

NOTES:  
 1. THIS SUBDIVISION WILL BE A PRIVATE DEVELOPMENT AND WILL BE MAINTAINED BY MONTRACHET HOMEOWNER'S ASSOCIATION  
 2. WATER AND SEWER TO SERVE THIS SUBDIVISION WILL BE CITY OF FORT WORTH WATER AND SEWER.

**CUL-DE-SAC LENGTH TABLE**

STREET NAME	LOT SIZES	STREET LENGTH (FEET)	NUMBER OF UNITS
STREET "B"	> 8,000 SF	526'	16
STREET "C"	> 8,000 SF	325'	11
STREET "F"	> 1.0 AC	1221'	14
STREET "K"	> 1.0 AC	732'	8
STREET "G"	> 1.0 AC	510'	6
STREET "H"	> 8,000 SF	619'	10
STREET "J"	> 1.0 AC	646'	6

L = 1,328.64'  
 Δ = 06°37'12"  
 R = 11499.16'  
 T = 665.04'  
 CH = S79°32'22"W  
 CL = 1,327.86'

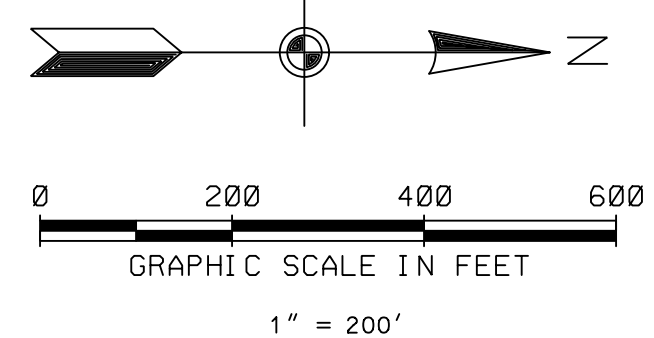

FINAL PLAT FOR  
**MONTRACHET**  
 LOTS 2-11, 13-18, 20-25, 27-41 & 1X, 12X, 19X, 26X, 42X, BLOCK 1,  
 LOTS 1-20 & 21X, BLOCK 2  
 LOTS 2-10, 12-24, & 1X, 11X BLOCK 3  
 LOTS 2-9 & 1X, BLOCK 4  
 LOTS 1-8, 10-20, 22-23 & 9X, 21X, 24X BLOCK 5  
 LOTS 1-13, 15-53 & 14X BLOCK 6  
 LOTS 1-8 & 9X BLOCK 7  
 AN ADDITION TO  
 TARRANT COUNTY, TEXAS  
 CITY OF FORT WORTH TEXAS (E.T.J.)  
 BEING 246.959 ACRES OF LAND  
 SITUATED IN THE  
 J. F. ELLIOTT SURVEY, ABSTRACT NO. 493  
 JOHN BURSEY SURVEY, ABSTRACT NO. 128  
 AND NANCY CASTEEL SURVEY, ABSTRACT NO. 349  
 FORT WORTH (E.T.J.), TARRANT COUNTY, TEXAS

REVISIONS

PROJECT NO.	DATE	APPROVED BY
180250	APA	EK
		DATE

PRELIMINARY PLAT FOR MONTRACHET

A.N.A. CONSULTANTS, L.L.C.  
 5000 Thompson Terrace  
 Colleyville, Texas 76034  
 Office: (817) 335-9900  
 Fax: (817) 335-9955  
 F.R.NO. 100980

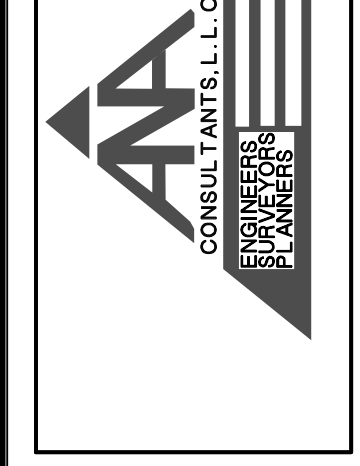

SHEET 1 OF 2  
 PP-19-005  
 AX-19-004  
 ZC-19-020