

This document was prepared under 22 TAC 663.21, does not reflect the results of an on the ground survey, and is not to be used to convey or establish interests in real property except those rights and interests implied or established by the creation or reconfiguration of the boundary of the political subdivision for which it was prepared.

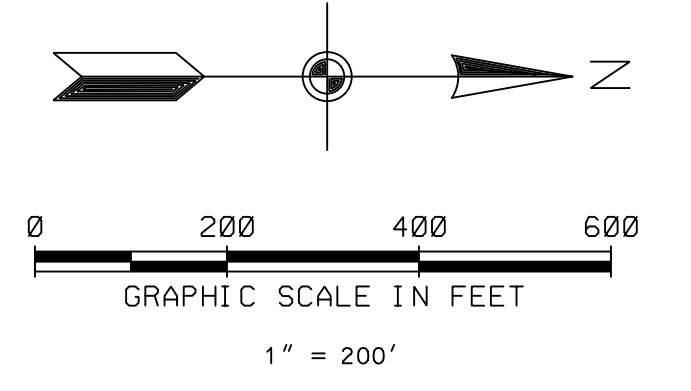

DAVID JONES
 CHERYL M. JONES
 VOL. 15898, PG. 131
 D.R.T.C.T.
 (52.717 ACRES)

ZONED "AG"

OWNER/DEVELOPER
 MONTSERRAT HILLS, LLC.
 6000 WESTERN PLACE, SUITE 465
 FORT WORTH, TEXAS 76107
 TEL. (817) 377-8827
 FAX (817) 732-0595

ZONING EXHIBIT SHOWING
 245.922 ACRES OF LAND
 SITUATED IN THE
 J. F. ELLIOTT SURVEY, ABSTRACT NO. 493
 JOHN BURSEY SURVEY, ABSTRACT NO. 128
 AND NANCY CASTEEL SURVEY, ABSTRACT NO. 349
 FORT WORTH (E.T.J.), TARRANT COUNTY, TEXAS

EXISTING ZONING "NOT ZONED"
 PROPOSED ZONING "A-43 & A-21"
 PREPARED JANUARY 2019

PROJECT NO.	DATE	REVISIONS
180450		
DRAWN BY		
APPROVED BY		
DATE		

ZONING EXHIBIT SHOWING
 FOR
 MONTRACHET

A.N.A. CONSULTANTS, L.L.C.
 5000 Thompson Terrace
 Colleyville, Texas 76034
 Office: (817) 335-9900
 Fax: (817) 335-9955
 TSPE FIRM # 20
 F.R.NO. 1009080

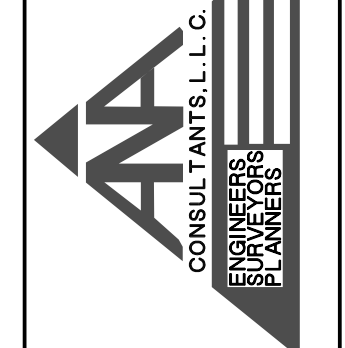

ZC-19-020

AX-19-004
 PP-19-006

Copyright © 2019 by A.N.A. Consultants, L.L.C.
 180250_Zoning.dgn 2/25/2019 1:57:41 PM